

TEMPLEFORCE



DEFENSE & SECURITY
CONSULTANTS

SPECIAL VEHICLES

TF-X4 “Kile” For Armed Forces

Recommended & Enforced Products

TEMPLEFORCE



TFX 4x4 Special Operation Vehicle



“KYLE”



TFX 4x4 Special Operation Vehicle



TEMPLEFORCE



TFX 4x4 Special Operation Vehicle





TFX 4X4 - THECNICAL DATA

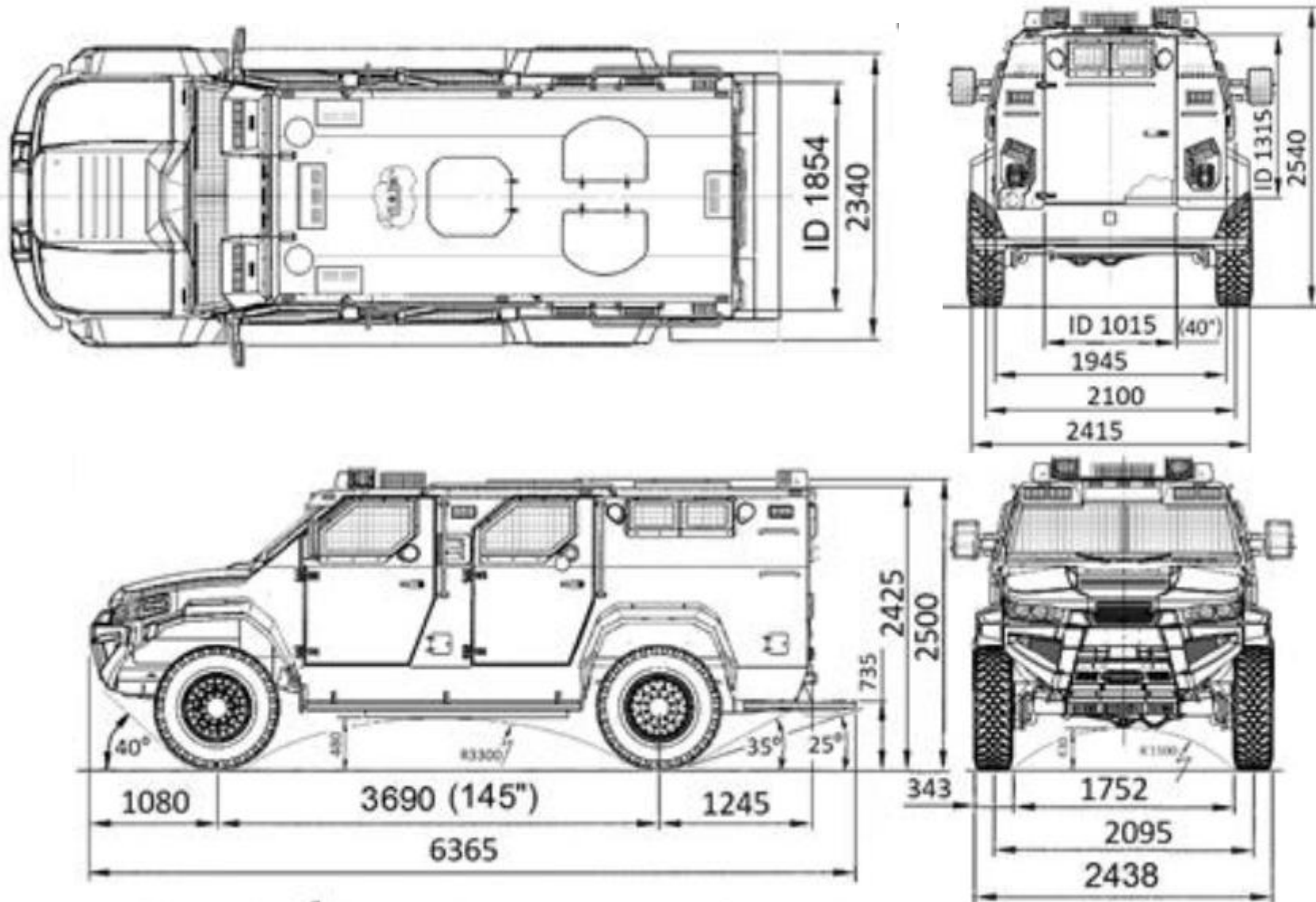



TFX 4X4 - THECNICAL DATA

Base Vehicle Specification

Base vehicle	: 2020 Ford F550, 4x4, 145 " WB
Engine	: 6.7 liters V8, Turbo Diesel
Power	: 330hp @ 2600 rpm
Torque	: 1017 Nm @ 2000 rpm
Total length	: 6,365 mm (including front and rear bumpers)
Width	: 2,438 mm (without mirrors)
Height	: 2,500 mm
GVWR	: 8,845 kg
Load capacity	: 1,500 kg
Transmission	: 6-speed automatic, electronically controlled (TorqShift)
Traction	: 4x4
Front suspension	: Solid axle with reinforced coil spring, high-resistance Horstman shock absorbers and bump stops
Rear suspension	: Reinforced elliptical leaf springs with bumps stops and Horstman shock absorbers
Steering	: Power steering with Horstman HD steering damper
Tires and wheels	: 335/85 R20 o R20 12.5, wheels 20 x 11
Brakes	: Disk brakes on 4 wheels, ABS
Accessories	: radio AM / FM, OEM cab A/C, rear operating high output A/C, GPS
Body	: 10 Passengers monoblock body, from hardened steel, 1/4 thickness, welded flat panels. Achieved protection level – BR6.
Glasses	: 40mm thickness, layered Glass, protection level BR6.
Electric	: Dual battery, 3 internal dome lights, siren system, 8 strove lights, 2 Go-Lights, reverse camera.
Seating options	: OEM driver and passenger adjustable sits, 2 Flip seats, 2 side bench seats.
Additional equipment	: Engine and wheel fire suppression Firetrace system, winch Warn VR10, GPS on-board system, 2 hydraulic jacks.
Color	: Black

Application details

- Vehicle body, monobloc type, is fully encapsulated to provide armor protection for occupants at all points.
- The whole body is made of welded ballistic grade steel, bolted to the chassis through HD bushings, in addition to highly efficient front and rear shock absorbers Horstman, as well as steering damper – provide improved ergonomics characteristics.
- Five side shielding of the passenger compartment (roof and uprights) to provide protection against NATO 7.62x51mm M80 ammunition, in accordance with CEN-BR6 Shielding level, with zero angle of obliquity.
- The floor is equipped with explosion protection to protect the occupants against the fragmentation of the detonation of 2 DM-51 hand grenades German ammunition or equivalent antipersonnel mines.
- Specific design and manufacturing techniques are used that allow a significant cost reduction for the customer while maintaining structural integrity and ballistic resistance level as well as center of gravity optimization to provide extremely good maneuverability for a vehicle of this nature.
- The interior frame, constructed of ballistic steel, offers overlapping and protection protection for major areas of large surface impact, such as doors and windows. It also reinforces the structural integrity of the supporting pillars and other areas that are crucial to maintaining the safety of vehicles in all circumstances.
- Vehicle shielding has been constructed in such a way as to ensure that a projectile following a linear or angled path will not enter the interior of the vehicle without contacting the armoured material. In addition to this, the possibility of a projectile entering the vehicle interior due to rebounding of the armouring will also be minimized.

Body mount suspension schematics

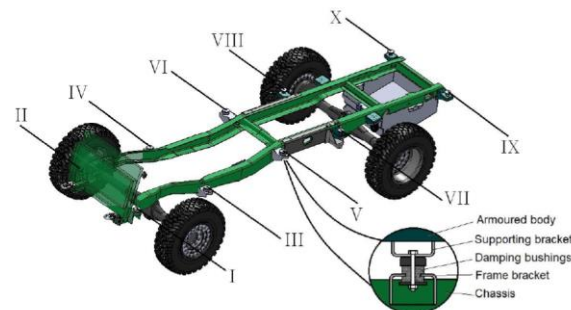



TFX 4X4 – Armor Conversion Modifications / Alterations

- Vehicle body, monobloc type, is fully encapsulated to provide armor protection for occupants at all points.
- The whole body is made of welded ballistic grade steel, bolted to the chassis through HD bushings, in addition to highly efficient front and rear shock absorbers Horstman, as well as steering damper – provide improved ergonomics characteristics.
- Five side shielding of the passenger compartment (roof and uprights) to provide protection against NATO 7.62x51mm M80 ammunition, in accordance with CEN-BR6 Shielding level, with zero angle of obliquity.
- The floor is equipped with explosion protection to protect the occupants against the fragmentation of the detonation of 2 DM-51 hand grenades German ammunition or equivalent antipersonnel mines.
- Specific design and manufacturing techniques are used that allow a significant cost reduction for the customer while maintaining structural integrity and ballistic resistance level as well as center of gravity optimization to provide extremely good maneuverability for a vehicle of this nature.
- The interior frame, constructed of ballistic steel, offers overlapping and protection protection for major areas of large surface impact, such as doors and windows. It also reinforces the structural integrity of the supporting pillars and other areas that are crucial to maintaining the safety of vehicles in all circumstances.
- Vehicle shielding has been constructed in such a way as to ensure that a projectile following a linear or angled path will not enter the interior of the vehicle without contacting the armoured material. In addition to this, the possibility of a projectile entering the vehicle interior due to rebounding of the armouring will also be minimized.

